



RelComm, Inc.

---

October 2013

---

# ***i*-COS User's Manual**

***integrated Code Operated Switch***

---

***i*-COS Configurations  
4, 8, 12 & 16 Ports  
RS - 232  
RS - 422**



## WARNINGS



When you are working within the unit, be certain that the power is disconnected. High voltages that can cause electrical shock are present on the power supply when power is applied.

This equipment generates, uses and can radiate radio frequency energy and, if not installed and used in accordance with this Instruction Manual, may cause interference to radio communications. It has been tested and found to comply with the limits for a Class A computing device pursuant to Subpart J of Part 15 of FCC Rules, which are designed to provide reasonable protection against such interference when operated in a commercial environment. Operation of this equipment in a residential area is likely to cause interference, in which case the user, at user's expense, will be required to take whatever measures may be required to correct the interference.

## LIMITED WARRANTY

RelComm, Inc., hereafter referred to as RCI, warrants this Product to be in good working order for a period of One (1) Year from the date of purchase from RCI. NO WARRANTIES, WHETHER EXPRESS OR IMPLIED, WILL APPLY AFTER THIS PERIOD.

Should this Product fail to be good working order at any time during this warranty period, RCI will, at its option, repair or replace this product at no additional charge except as set forth below. Repair parts and replacement Products will be furnished on an exchange basis and will be either reconditioned or new. This limited warranty does not include service to repair damage to the Product resulting from accident, disaster, misuse, abuse, or non-RCI modification of the Product.

Limited Warranty service may be obtained by delivering the Product during the warranty period to RCI and providing proof of purchase date. If this Product is delivered by mail, you agree to:

- a) insure the Product or assume the risk of loss or damage in transit,
- b) prepay shipping charges to the warranty service location, and
- c) re-use the original shipping container or equivalent.

SOME STATES DO NOT ALLOW LIMITATIONS ON HOW LONG AN IMPLIED WARRANTY LASTS, SO THE ABOVE LIMITATIONS MAY NOT APPLY TO YOU.

IF THIS PRODUCT IS NOT IN GOOD WORKING ORDER AS WARRANTED ABOVE, YOUR SOLE REMEDY SHALL BE REPAIR OR REPLACEMENT AS PROVIDED ABOVE. IN NO EVENT WILL RCI BE LIABLE TO YOU FOR ANY DAMAGES, INCLUDING ANY LOST SAVINGS OR OTHER INCIDENTAL OR CONSEQUENTIAL DAMAGES ARISING OUT OF THE USE OF OR INABILITY TO USE SUCH PRODUCT, EVEN IF RCI OR AN AUTHORIZED DEALER HAS BEEN ADVISED OF THE POSSIBILITY OF SUCH DAMAGES, OR ANY CLAIM BY ANY OTHER PARTY.

SOME STATES DO NOT ALLOW THE EXCLUSION OR LIMITATION OF INCIDENTAL OR CONSEQUENTIAL DAMAGES FOR CONSUMER PRODUCTS, SO THE ABOVE LIMITATIONS OR EXCLUSIONS MAY NOT APPLY TO YOU.

THIS WARRANTY GIVES YOU SPECIFIC LEGAL RIGHTS, AND YOU MAY ALSO HAVE OTHER RIGHTS WHICH MAY VARY FROM STATE TO STATE.

For further information, contact:

RelComm Service  
P.O. Box 640  
4868 highway 4, Suite G  
Angels Camp, CA 95222

on the Web: [www.relcomm.com](http://www.relcomm.com)

Email: [rcinfo@relcomm.com](mailto:rcinfo@relcomm.com)

Phone: (209) 736-0421  
FAX: (209) 736-0425  
Toll-Free: (800) 222-2810

EIA-CITT MODEM TABLE (DCE) – TERMINAL (DTE) – INTERFACE

Table of Contents

PIN	NAME	DTE DCE	FUNCTION	CIRCUIT	
				CCITT	(EIA)
1	FG		FRAME GROUND	101	(AA)
2	TD	→	TRANSMITTED DATA	103	(BA)
3	RD	←	RECEIVED DATA	104	(BB)
4	RTS	→	REQUEST TO SEND	105	(CA)
5	CTS	←	CLEAR TO SEND	106	(CB)
6	DSR	←	DATA SET READY	107	(CC)
7	SG		SIGNAL GROUND	102	(AB)
8	DCD	←	DATA CARRIER DETECT	109	(CF)
9		←	POSITIVE DC TEST VOLTAGE		
10		←	NEGATIVE DC TEST VOLTAGE		
11	QM	←	EQUALIZER MODE	BELL 208A	
12	(S)DCD	←	SEC. DATA CARRIER DETECT	122	(SCF)
13	(S)CTS	←	SEC. CLEAR TO SEND	121	(SCB)
14	(S)TD	→	SEC. TRANSMITTED DATA	118	(SBA)
	NC	→	NEW SYNC	BELL 208A	
15	TC	←	TRANSMITTER CLOCK	114	(DB)
16	(S)RD	←			
	DCT	←	DIVIDED CLOCK TRANSMITTER	BELL 208A	
17	RC	←	RECEIVER CLOCK	115	(DD)
18	DCR	←	DIVIDED CLOCK, RECEIVER	BELL 208A	
19	(S)RTS	→	SEC. REQUEST TO SEND	120	(SCA)
20	DTR	→	DATA TERMINAL READY	108.2	(CD)
21	SQ	←	SIGNAL QUALITY DETECT	110	(CG)
22	RI	←	RING INDICATOR	125	(CE)
23		→	DATA RATE SELECTOR	111	(CI)
		←	DATA RATE SELECTOR	112	
24	(TC)	→	EXT. TRANSMITTER CLOCK	113	(DA)
25		→	BUSY		

POSITIVE VOLTAGE EQUALS A BINARY “ZERO” OR A SIGNAL “SPACE” OR A CONTROL SIGNAL “ON”

NEGATIVE VOLTAGE EQUALS A BINARY “ONE” OR A SIGNAL “MARK” OR A CONTROL SIGNAL “OFF”

GRAY ON THIS TABLE INDICATES “NOT USED”

**SECTION 1 – INTRODUCTION..... 4**

    1.1 GENERAL.....4

        1.1.1 DEFINITIONS.....4

    1.2 OPERATIONAL DESCRIPTION .....4

    1.2 SPECIFICATIONS .....6

**SECTION 2 – INSTALLATION ..... 8**

    2.1 GENERAL.....8

        2.1.1 INSTALLATION of the RACK-MOUNTABLE UNIT .....8

    2.2 SWITCH SETTINGS.....9

        2.2.1 RS232 PORT CONFIGURATION SWITCHES .....9

        2.2.2 AUTO-TIMEOUT, SWITCH TIME & RS 232/422 .....13

        2.2.3 HANDSHAKE CONTROL, PORT DECODER & POWER-ON RESET ..... 13

        2.2.4 DATA FORMAT .....14

        2.2.5 POWER-ON PORT SELECTION & GRAPHICS MODE..... 14

        2.2.6 ARMING CODE SETTINGS ..... 15

**SECTION 3 – OPERATION..... 19**

    3.1 POWERING THE UNIT ..... 19

        3.1.1 FRONT PANEL INDICATORS..... 19

    3.2 ARMING CHARACTER & PORT SELECT CHARACTER ..... 19

    3.3 COMMUNICATION ERROR CONDITIONS.....20

    3.4 AUTO TIME OUT .....20

    3.5 RESET BUTTON.....21

    3.6 LOCK-OUT.....21

    3.7 MODES OF OPERATION .....21

        3.7.1 TEXT MODE.....21

        3.7.2 TRANSPARENT MODE.....21

        3.7.3 GRAPHICS MODE.....22

    3.8 TROUBLESHOOTING .....22

    3.9 i-COS 4/8/12/16 PORT INFORMATION .....23

    3.10 BASIC TEST PROGRAM FOR THE i-COS.....24

    NOTES .....24

NOTES.....25

EIA-CITT MODEM TABLE (DCE) – TERMINAL (DTE) – INTERFACE .....26

LIMITED WARRANTY .....27

**SECTION 1 - INTRODUCTION**

**1.1 GENERAL**

The Integrated Code Operated Switch (*i*-COS) is an asynchronous RS232C and/or RS422 switch, available in configurations of 4, 8, 12 and 16 subordinate-ports with one master port. For information or to order multiple-port devices, please contact your sales source, or see our contact information on page 27 in this manual.

The *i*-COS can be configured RS232 on all Ports, RS422 on all Ports, or a combination (Master RS232 and all Subordinate Ports RS422, or Master RS422 and all Subordinate Ports RS232). *i*-COS/4 may be configured as RS422 in the field; *i*-COS/8, /12 and /16 must be configured RS422 at the factory, requested at the time an order is placed or return retro-fit. It is recommended that the user examine the original purchasing documents to verify the configuration of the unit as received.

Additionally, the *i*-COS may be configured with an optional internal modem (RS232 only), available at time of order or as a factory upgrade.

**1.1.1 DEFINITIONS** (definitions for industry standard RS 232/422 are not included)

- |   |   |
|---|---|
| <b>FE:</b> Framing Error                        | <b>PE:</b> Parity Error                           |
| <b>TRE:</b> Transmit Register Empty             | <b>CIN:</b> Control In                            |
| <b>M</b> or <b>M-Port:</b> Master Port          | <b>S</b> or <b>S-Port:</b> Subordinate/Slave Port |
| <b>ST:</b> Switch Time                          | <b>CD:</b> Carrier Detect                         |
| <b>LSB</b> or <b>lsb:</b> Least Significant Bit | <b>MSB</b> or <b>msb:</b> Most Significant Bit    |

**1.2 OPERATIONAL DESCRIPTION**

Under code control, the Master Port can select any of the Subordinate Ports by transmitting the proper control and switch address code. The Master device (CPU/Terminal) selects any of the other Ports (Printers/modems/terminals) by transmitting the proper arming and switching code. A communications link to the Master Port can also be made by any of the subordinate devices by transmitting its own port address code while the switch is in the Switch Time. Once the communications link is established, all other Ports are locked out. The Ports remain locked out until either the Master Port or the selected Subordinate Port *transmits* an arming character. Reception of the arming character causes the *i*-COS to break all switched connections between the Master and Subordinate Ports and places the unit back into Switch Time.

The typical TEXT mode transmission pattern is:

<ARMING CODE, PORT ADDRESS CODE, DATA.....>

### 3.10 BASIC TEST PROGRAM FOR THE *i*-COS

Connect the PC to the Master Port and run the following program using either BasicA or GW Basic.

```

10 REM***** CODE ACTIVATED SWITCH TEST *****
20 OPEN "COM1: 9600,N,8,1,CS,DS" AS1 :REM** SET UP COM 1 PC PORT**
30 P=48 :REM**SET PORT # TO 1(DECIMAL 48)**
40 PRINT #1, CHR$(4); :REM**SEND ARMING CHAR**
50 PRINT #1, CHR$(P); :REM**SEND PORT # OUT COM 1 **
60 T=P-48 :REM**CONVERT DEC. TO ACTUAL PORT # **
70 PRINT #1, "THIS IS A TEST OF PORT#"T :REM**SENDS MESSAGE OUT COM 1**
80 FOR I=I TO 250 :REM**DELAY **
90 NEXT I :REM**LOOP**
100 P=P+1 :REM**INCREMENT PORT # **
110 IF P=52 THEN GOTO 30 ELSE GOTO 40 :REM**LOOP BACK FOR NEXT PORT**

```

**NOTE**

REM statements are optional. Semi- colons are required at the end of lines 40 and 50 to inhibit CR.

**NOTES**

All Ports have female DB25S connectors. Configuration switches on all ports allow configuration to a Data Terminal Equipment (DTE) or Data Computer Equipment (DCE). The device also allows configuration of many user-selectable features, including: word length, baud rate, stop bits, DCE/DTE, control handshake, graphics, arming character, transparent mode, inactivity timeout, default power-up and lockout.

Figure 1-1 shows a typical network involving various peripherals. The computer selects which device it wishes to communicate with by transmitting the proper arming and port switching code. If desired, the connection can be made from a terminal (if these devices know the proper codes).

The *i*-COS will also work in applications where the arming character can appear in the data stream (such as graphics, and error checking). When in graphics mode, a switch-selectable idle time after the data stream is required before the arming character is valid. If an arming character is in the data stream, it will pass without causing the *i*-COS to switch.

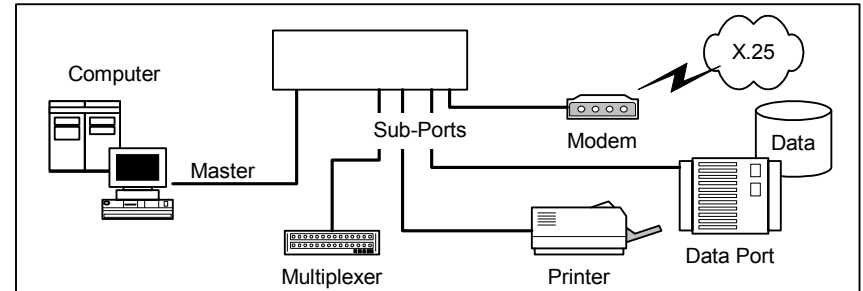

**Figure 1-1. Typical Application**

## 1.2 SPECIFICATIONS

Note: measurements are shown in both English & (Metric)

<b>Interface:</b>	RS232/V.24, Full Duplex, Asynchronous and/or RS422/V.11, Full Duplex, Asynchronous
<b>External Connectors:</b>	Female DB25 (Master Port and Subordinate Ports)
<b>External Controls:</b>	MODE toggle switch; RESET push button switch
<b>Internal Controls:</b>	Many functional parameters are switch selectable, including:  <b>High Baud (Bd) Rate:</b> 1200, 4800, 9600, 19.2K, 38.4K, 57.6K, 76.8K, 115.2K <i>Note: Low Baud Rate (300 &amp; 2400 through 76,800) available on special order or contact factory.</i>  <b>Word Format</b> (7 or 8 Data bits; 1 or 2 Stop bits; Odd or Even Parity, enabled or disabled)  <b>Port Configuration:</b> DTE/DCE and Control Handshake configurable for each port  <b>Auto Timeout:</b> (0.5 minutes, 1.5 minutes, 7.3 minutes or disabled/infinite)  <b>Arming Character:</b> (switch selectable by the user)
<b>Indicators:</b>	LED's for <b>SWITCH TIME &amp; LOCK-OUT</b> ; Bi-color LED's for Master Port <b>DATA</b> and <b>CONTROL</b> status; 7-segment Port Display for <b>PORT SELECTED, WatchDog</b> and <b>COMMUNICATION ERRORS</b>
<b>Internal Connectors:</b>	<b>AS</b> (Active Serial) and <b>JTAG</b> (Joint Test Action Group) for programming; <b>AEX:</b> ASIC signals access (future use); <b>J6 - J8:</b> 4-port expanders; <b>P1:</b> modem port; <b>J9:</b> modem power
<b>Port Addressing:</b>	Code in the data stream assigns/selects the port.
<b>Power:</b>	100 - 130 VAC fuse: Littelfuse 3AG Slo-Blo 313P series, 500 mA (or equivalent), 50 - 60 Hz, 11 watts.  200 - 240 VAC fuse: Littelfuse 3AG Slo-Blo 313P series, 250 mA (or equivalent), 50 - 60 Hz, 11 watts.

### WARNING



**Primary Voltage Selection and Fuse may be changed by a qualified technician.**

<b>Humidity:</b>	15% to 95% Non-condensing
<b>Temperature:</b>	Operating: +32°F to 104°F (0°C to 40°C) Storage: - 40°F to 158°F (-40°C to 70°C)

## 3.9 I-COS 4/8/12/16 PORT INFORMATION

The following chart indicates the Port Address Characters (also called Port Address Codes) used to select a port. In the data stream, the Port Address Character follows the Arming Code to select/assign the corresponding port (reference paragraph 3.2).

Port No.	Port Addr Character		Numeric Display	Board I/O
	ASCII	Hex		
0	0	30	0	Main-0
1	1	31	1	Main-1
2	2	32	2	Main-2
3	3	33	3	Main-3
4	4	34	4	J6-0
5	5	35	5	J6-1
6	6	36	6	J6-2
7	7	37	7	J6-3
8	8	38	8	J7-0
9	9	39	9	J7-1
10	:	3A	:	J7-2
11	;	3B	;	J7-3
12	<	3C	<	J8-0
13	=	3D	=	J8-1
14	>	3E	>	J8-2
15	?	3F	?	J8-3

### 3.7.3 GRAPHICS MODE

**(DOWN switch position)** The GRAPHICS mode is capable of passing graphics data while still maintaining code control.

In this mode, an arming character will only be recognized as an arming character if it is preceded by a pause in data transmission of a required minimum length of time, user selected via SW-P, positions 5 and 6. Any arming character not preceded by this pause will be passed as data (see Section 2.2.5).

This pause is measured in one of three ways:

1. From the time the last character was sent from the Master Port to the Subordinate Port (SW-P Position 7 CLOSED, Position 8 OPEN – refer to Section 2.2.5).
2. From the time the last character was sent from the Subordinate Port to the Master Port (SW-P Position 7 OPEN, Position 8 CLOSED).
3. From the time the last character was sent in either direction (SW-P Position 7 CLOSED, Position 8 CLOSED). To disable the pause reset, set SW-P positions 7 and 8 OPEN.

### 3.8 TROUBLESHOOTING

**Blinking Decimal Point** – a blinking right decimal point on the Port Display indicates the ASIC has failed to load from the PROM. Power down the unit, wait for a few seconds then power on again. If the decimal point continues to blink, return the unit for analysis.

**Unit Switches On Its Own** – If the *i*-COS appears to switch on its own, it is most likely receiving an arming character in the data stream. If the switching control should only come for the Master Port or only come from the Subordinate Port, disable the port which is not being used for switching (SW-T Positions 3 thru 6 – See paragraph 2.2.2), or try running GRAPHICS mode.

**Bit Loss** – If occasional bit loss occurs, try running 2 stop bits on the computer equipment (with the *i*-COS unit set to receive 1 stop bit).

**Will Not Pass Data/Will Not Switch** – If data does not pass and the *i*-COS will not switch, check the cables and the port switches (SWA, SWB).

**Communication Errors** – Reference section 3.3.

- Enclosure:**
- a) Aluminum, NEMA Standard 19 inch rack mount
  - b) Plastic, standalone (*i*-COS/4 or /8 only)

### 1.2 SPECIFICATIONS (continued)

- Size:**
- Rack mount:
- *i*-COS/4 or /8: 19" W x 10.75" D x 3.5" H; (48.26 cm W x 27.31 cm D x 8.89 cm H); 2-RETMA vertical rack space
  - *i*-COS/12 or /16: 19" W x 10.75" D x 5.25" H; (48.26 cm W x 27.31 cm D x 13.34 cm H); 3-RETMA vertical rack space
- Standalone:
- 12.25" W x 11.75" D x 2.5" H; (31.115 cm W x 29.845 cm D x 6.35 cm H)
- Weight:**
- Rack mount: 5.5 pounds (2.5 kg)
- Standalone: 4.0 pounds (1.8 kg)

Each port is highly configurable by setting internal switches, to allow compatibility with the equipment attached to the port.

### RS232

Pin No.	Name	Description
1	FG	Chassis Ground, wired straight through
2	TD	Selectable to be DTE (Data Out) or DCE (Data In)
3	RD	DTE/DCE switch selectable for each port
4	RTS	Selectable to be open, pulled up, Control In or Control Out, or tied to pin 5
5	CTS	Switch selected to be pulled up or tied to pin 4
6	DSR	DTE/DCE switch selectable for each port
7	SG	Signal return, wired straight through
8	DCD	Received line signal detector; switch selectable to be pulled up or not pulled up, Control In or Control Out
20	DTR	DTE/DCE switch selectable for each port

### RS422

Pin No.	Description	Pin No.	Description
12	Control in low	18	Data in high
13	Control in high	19	Data in low
14	Control out high	24	Data out high
15	Control out low	25	Data out low

## SECTION 2 – INSTALLATION

### 2.1 GENERAL

Installation of the *i*-COS is a matter of connecting the Master and Subordinate ports to the proper communications equipment using the DB25 (female) connectors.

For RS232 operation, internal DIP port configuration switches allow the user to individually configure each port for either DTE or DCE operation, as necessary. For RS422, operation is independent of the port switch settings. **Note: Only the Master Port and S-Ports 0 – 3 are configurable in the field as RS422; S-Ports 4 – 15 must be configured RS422 at the factory.**

When viewing the *i*-COS from the rear panel:

- *i*-COS/4 – the left most connector is the Master Port; the Subordinate Ports connectors are numbered from left to right 0, 1, 2 and 3
- *i*-COS/8 – additional Subordinate Ports connectors left to right 4, 5, 6 and 7
- *i*-COS/12 – additional Subordinate Ports connectors left to right 8, 9, 10 and 11
- *i*-COS/16 – additional Subordinate Ports connectors left to right 12, 13, 14 and 15

Reference the enclosed Addendum “Factory Presets” to note the unit’s internal switch settings preset at the factory. Determine if any internal switches must be reconfigured to match your particular application.

#### 2.1.1 INSTALLATION of the RACK-MOUNTABLE UNIT

The rack-mount unit is designed to fit a NEMA Standard 19 inch rack. Install this unit using all four mounting holes. The cover helps stiffen the entire unit, therefore before installation, insure all cover screws are tight.

After installation, dress cables in such a manner that they do not apply excessive strain on the cable connectors.

### 3.4 AUTO TIME OUT

If Auto Timeout is enabled, the *i*-COS will time out after an idle time as selected by switch SW-T, and return to Switch Time. Data in either direction will continually reset the timer. To disable Auto Timeout, set the time to “infinite”.

**NOTE**

*If AUTO TIMEOUT is selected, the unit will revert to Switch Time after the selected timeout.*

### 3.5 RESET BUTTON

The reset button will force the unit into Switch Time or to a Port, as selected by Switch-P (reference page 14).

### 3.6 LOCK-OUT

When the unit is in Lock-Out, the front panel “LO” LED will illuminate, and the Port Display will indicate the letter “L”. The Subordinate Ports can not access the Master Port. Lock-Out is controlled exclusively by the Master Port. The *i*-COS can be put into Lock-Out during the Switch Time when:

For COS/4 and /8 units: SW-C, pos 8 Closed, and a 38 HEX (or greater) character is transmitted at the Master Port.; For COS/12 and /16 units: SW-C, pos 8 Open, and a 70 HEX (or greater) character is transmitted at the Master Port.

To get out of Lock-Out, transmit the arming character. When emerging from LOCK-OUT, both the LO and ST LEDs will be lit until a port is selected; Port Display is blanked.

### 3.7 MODES OF OPERATION

The *i*-COS can operate in one of three modes: TEXT, TRANSPARENT, or GRAPHICS. The MODE front panel toggle switch is used to select the desired mode.

#### 3.7.1 TEXT MODE

**(UP switch position)** In the TEXT mode, the *i*-COS will enter Switch Time whenever it receives an arming character. The unit will select the Subordinate Port that is specified by the port select character. The remaining text will pass through the unit until another arming character is encountered. The arming character and the port select character will not pass through the unit in this mode. It is the user’s responsibility to choose an arming character that will never appear as part of the text.

#### 3.7.2 TRANSPARENT MODE

**(MIDDLE switch position)** In the TRANSPARENT mode, all data including the arming and port selection character will pass through the unit to and from the Master and the Subordinate Ports that were selected before entering this mode. This mode totally disables code control, and all characters printable and non-printable are passed.



### ARMING CHARACTER

This character is user selected and entered via DIP switch SW-A (See chart in paragraph 2.2.6). The arming character may be set as the equivalent of an ASCII, CTRL, HEX or Decimal character. For example, the arming character may be any one of the following CTRL characters: @, A, B, C, D, E.

When the *i*-COS receives the arming character within the data stream, it will enter an armed state known as Switch Time, and the "ST" LED on the front panel will be illuminated.

### PORT SELECT CHARACTER

The port select character is the first character received after the arming character, and determines which Subordinate Port will be selected – the port select character can only be recognized as such by its position in the data stream.

With the PORT16 switch (SW-C, position 8), set False (Closed), only the least significant four bits are used in the decoding. Therefore, port selection is limited to Port 0 through Port 7. For example, for ports 0 – 3, the port select character is ASCII 0 through 3 (30 HEX through 33 HEX). Reference the charts in paragraph 2.2.6 and paragraph 3.9.

With the PORT16 switch set True (Open), all eight bits are used in the decoding. Therefore, port selection is enabled for all ports 0 through 15.

## 3.3 COMMUNICATION ERROR CONDITIONS

Under normal conditions where no communication errors are detected, the Port Display provides the normal indications as shown in paragraph 3.1.1 above.

When an error is detected, the Port Display is multiplexed to show the port address for approximately one second, and then an error symbol (Figure 3–1 below). This alternating display remains for approximately five seconds and then returns to the normal display, providing that there are no additional errors detected.

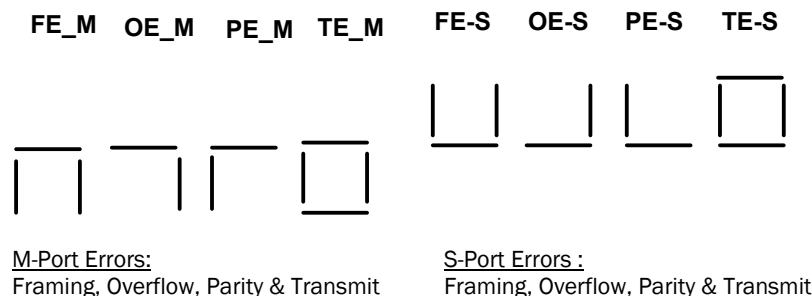

Figure 3–1. Port Display Error Indications

## 2.2 SWITCH SETTINGS

### WARNING



**IF ANY INTERNAL DIP SWITCH SETTINGS MUST BE CHANGED, BE CERTAIN THAT THE POWER IS DISCONNECTED FROM THE UNIT BEFORE REMOVING THE COVER.**

Refer to Figure 2-1 for the location of the switches. In the following switch descriptions, a closed switch may be shown as "CLOSED", "C" or "CL", and an open switch may be shown as "OPEN", "O" or "OP".

### 2.2.1 RS232 PORT CONFIGURATION SWITCHES (SWA1 through SWA5; and SWB1 through SWB5)

Every port has a pair of eight-position DIP configuration switches (switch A and switch B) to select which pins are set to provide the required combination of inputs, outputs and control handshaking for RS232 (not required for RS422).

A **DTE** (**D**ata **T**erminal **E**quipment) device transmits data on pin 2 and receives data in on pin 3. The control output pins are pin 4 (RTS) and pin 20 (DTR). The control input pins are pin 5 (CTS), pin 6 (DSR) and pin 8 (DCD). Terminals, personal computers, DEC computers are examples of DTE devices.

A **DCE** (**D**ata **C**ommunication **E**quipment) device is the converse of DTE, that is, a DCE transmits data on pin 3 and receives data in on pin 2. The control output pins are pin 5 (CTS), pin 6 (DSR) and pin 8 (DCD). Modems, HP computers and DG computers are examples of DCE devices.

When connecting two devices together with a straight pinned serial cable, the devices must be converse types (one DTE and one DCE). Thus, the *i*-COS ports must be configured to be the converse type of the connecting device(s).

For the *i*-COS/4, switches SWA1/SWB1 are for the Master Port. Switches SWA2/SWB2 through SWA5/SWB5 are for Subordinate Ports 0-3 respectively. (If expansion boards are installed, the ports are controlled by the switches located directly behind each port.) See Figure 2-1, page 10.

In the following description, SWA is the left 8-position DIP switch and SWB is the right eight-position DIP switch as you look at the *i*-COS with the front panel facing you. See Figure 2-1, page 10.

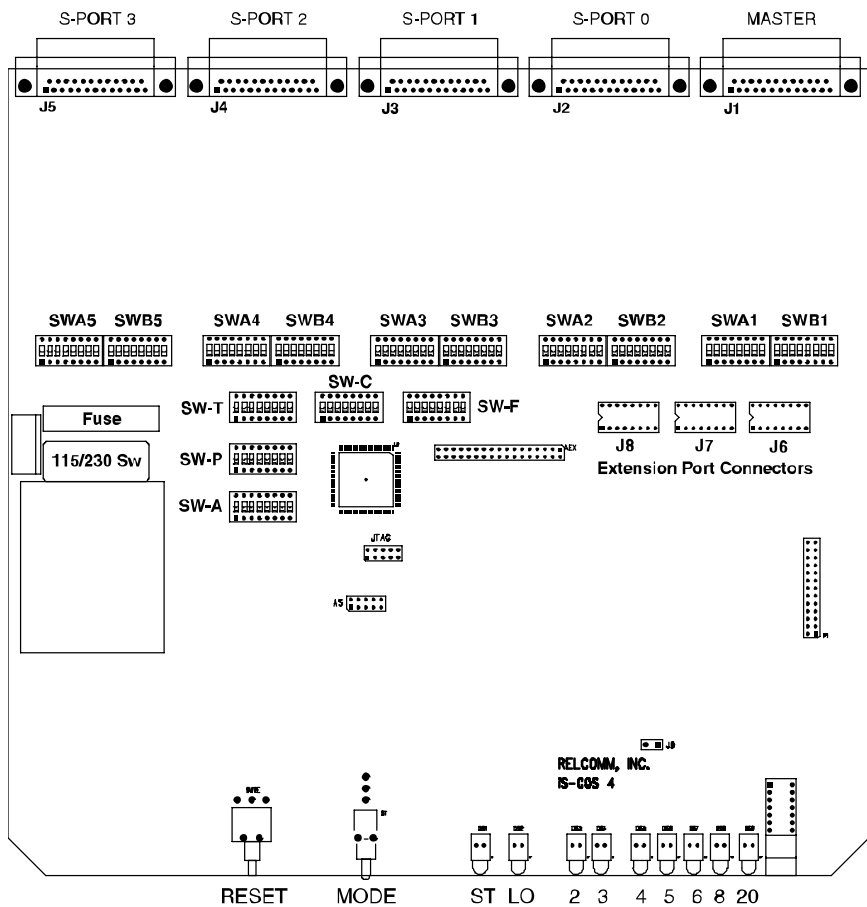

Figure 2-1. COMPONENT LAYOUT DIAGRAM

**Quick Set Up for switches SWA and SWB**

When connecting a modem or a host computer port (HP, DG), use the following settings and a straight pinned serial cable:

Switch Positions	1	2	3	4	5	6	7	8	(The port looks like DTE)
SWA	0	0	0	0	C	0	0	C	
SWB	0	C	C	0	C	C	C	C	

When connecting a PC, serial printer, or a dumb terminal (VT100, Wyse, Computer, etc.), use the following switch settings and a straight pinned serial cable:

Switch Positions	1	2	3	4	5	6	7	8	(The port looks like DCE)
SWA	0	0	0	0	0	C	C	0	
SWB	C	0	0	C	C	C	C	C	

**SECTION 3 – OPERATION**

**3.1 POWERING THE UNIT**

When power is first applied, note the status of the right decimal point on the Port Display. The right decimal point should indicate a steady ON (illuminated) state. If the right decimal point blinks, refer to Troubleshooting, section 3.8.

**3.1.1 FRONT PANEL INDICATORS**

The 7-segment Port Display exhibits the selected port; the LED's monitor the status of data and control handshake on pins 2 – 6, 8 & 20 of the Master Port - status of the pins are displayed with or without power applied to the i-COS. Indications are as follows:

Function	LED INDICATIONS		7-SEGMENT PORT DISPLAY *
Switch Time	ST	RED = Active OFF = Inactive	Port 0 – 3 = "0 – 3"
Lock-Out	LO	RED = Active OFF = Inactive	"L"
Data	2, 3	RED = Active (+) signal GREEN = Inactive (-) signal OFF = No signal	--
Control Handshake	4 – 6, 8, 20	GREEN = Active (+) signal RED or OFF = No signal	--
Port Selected	--	--	Port 0 – 3 = "0 – 3"
Power-on Status	--	--	Right decimal: ON = Power Good OFF = RESET BLINKING = Error

\* See chart in section 3.9 for i-COS/8, /12 & /16

**3.2 ARMING CHARACTER & PORT SELECT CHARACTER**

The arming and port addressing code consists of two characters in the form:

`arm_addr`; where,  
`arm` represents the arming character, and `addr` represents the port select character.

The arming character initiates Switch Time, and is immediately followed by the address character, which assigns the port. Any port can switch the port when the unit is in Switch Time, unless disabled by SW-T position 6. The arming and switching code is stripped by the Code Operated Switch. The Arming character can pass as data in Graphics mode.

## 2.2.6 ARMING CODE SETTINGS (continued)

### Switch SW-A

ARMING CHARACTERS				ARMING CHARACTER SWITCH POSITIONS							
ASCII	CTRL	HEX	DECIMAL	LSB 1	2	3	4	5	6	7	MSB 8
_		5F	95	0	0	0	0	0	C	0	C
`		60	96	C	C	C	C	C	0	0	C
a		61	97	0	C	C	C	C	0	0	C
b		62	98	C	0	C	C	C	0	0	C
c		63	99	0	0	C	C	C	0	0	C
d		64	100	C	C	0	C	C	0	0	C
e		65	101	0	C	0	C	C	0	0	C
f		66	102	C	0	0	C	C	0	0	C
g		67	103	0	0	0	C	C	0	0	C
h		68	104	C	C	C	0	C	0	0	C
i		69	105	0	C	C	0	C	0	0	C
j		6A	106	C	0	C	0	C	0	0	C
k		6B	107	0	0	C	0	C	0	0	C
l		6C	108	C	C	0	0	C	0	0	C
m		6D	109	0	C	0	0	C	0	0	C
n		6E	110	C	0	0	0	C	0	0	C
o		6F	111	0	0	0	0	C	0	0	C
p		70	112	C	C	C	C	0	0	0	C
q		71	113	0	C	C	C	0	0	0	C
r		72	114	C	0	C	C	0	0	0	C
s		73	115	0	0	C	C	0	0	0	C
t		74	116	C	C	0	C	0	0	0	C
u		75	117	0	C	0	C	0	0	0	C
v		76	118	C	0	0	C	0	0	0	C
w		77	119	0	0	0	C	0	0	0	C
x		78	120	C	C	C	0	0	0	0	C
y		79	121	0	C	C	0	0	0	0	C
z		7A	122	C	0	C	0	0	0	0	C
{		7B	123	0	0	C	0	0	0	0	C
		7C	124	C	C	0	0	0	0	0	C
}		7D	125	0	C	0	0	0	0	0	C
~		7E	126	C	0	0	0	0	0	0	C
DEL		7F	127	0	0	0	0	0	0	0	C

To configure a port's data and control leads, reference Tables 1 through 3 below. In general (not required for RS422):

- DCE or DTE data leads are selected via SWA positions 5 through 8
- Control handshaking is selected via SWA and SWB, positions 1 through 4.

The *i*-COS can pass one hardware control lead in both directions (M-Port to S-Port, S-Port to M-Port).

**Legend: C = Closed O = Open**

**Table 1 – DTE CONFIGURATION**

POSITIONS	SWA								SWB							
	1	2	3	4	5	6	7	8	1	2	3	4	5	6	7	8
FUNCTIONS																
DSR/DTR as Cin/Cout	0	0	0	0	C	0	0	C	0	C	C	0	See Table 3			
RTS/DCD as Cout/Cin	C	0	0	C	C	0	0	C	0	0	0	0	See Table 3			

**Table 2 – DCE CONFIGURATION**

POSITIONS	SWA								SWB							
	1	2	3	4	5	6	7	8	1	2	3	4	5	6	7	8
FUNCTIONS																
DSR/DTR as Cout/Cin	0	0	0	0	0	C	C	0	C	0	0	C	See Table 3			
RTS/DCD as Cin/Cout	0	C	C	0	0	C	C	0	0	0	0	0	See Table 3			

Additionally, Switch B, positions 5 through 8, are used to tie RTS to CTS, or pull RTS, CTS or DCD high:

**Table 3 – DCE CONFIGURATION**

POSITIONS	SWA								SWB							
FUNCTIONS																
Default																
Tie RTS to CTS																
RTS & CTS pulled high																
RTS pulled high																
CTS pulled high																
DCD pulled high																

2.2.6 ARMING CODE SETTINGS (continued)

Switch SW-A

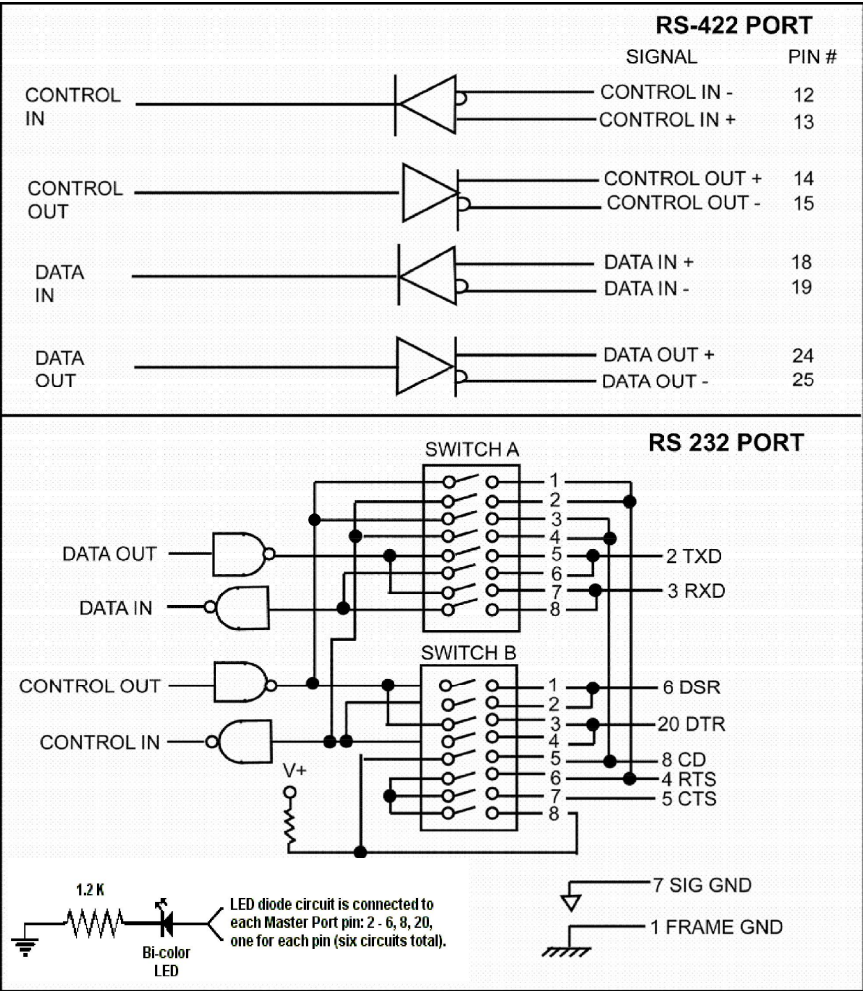

Figure 2-2. Port Configuration

ARMING CHARACTERS				ARMING CHARACTER SWITCH POSITIONS							
ASCII	CTRL	HEX	DECIMAL	LSB 1	2	3	4	5	6	7	MSB 8
?		3F	63	0	0	0	0	0	0	C	C
@		40	64	C	C	C	C	C	C	0	C
A		41	65	0	C	C	C	C	C	0	C
B		42	66	C	0	C	C	C	C	0	C
C		43	67	0	0	C	C	C	C	0	C
D		44	68	C	C	0	C	C	C	0	C
E		45	69	0	C	0	C	C	C	0	C
F		46	70	C	0	0	C	C	C	0	C
G		47	71	0	0	0	C	C	C	0	C
H		48	72	C	C	C	0	C	C	0	C
I		49	73	0	C	C	0	C	C	0	C
J		4A	74	C	0	C	0	C	C	0	C
K		4B	75	0	0	C	0	C	C	0	C
L		4C	76	C	C	0	0	C	C	0	C
M		4D	77	0	C	0	0	C	C	0	C
N		4E	78	C	0	0	0	C	C	0	C
O		4F	79	0	0	0	0	C	C	0	C
P		50	80	C	C	C	C	0	C	0	C
Q		51	81	0	C	C	C	0	C	0	C
R		52	82	C	0	C	C	0	C	0	C
S		53	83	0	0	C	C	0	C	0	C
T		54	84	C	C	0	C	0	C	0	C
U		55	85	0	C	0	C	0	C	0	C
V		56	86	C	0	0	C	0	C	0	C
W		57	87	0	0	0	C	0	C	0	C
X		58	88	C	C	C	0	0	C	0	C
Y		59	89	0	C	C	0	0	C	0	C
Z		5A	90	C	0	C	0	0	C	0	C
[		5B	91	0	0	C	0	0	C	0	C
\		5C	92	C	C	0	0	0	C	0	C
]		5D	93	0	C	0	0	0	C	0	C
^		5E	94	C	0	0	0	0	C	0	C

## 2.2.6 ARMING CODE SETTINGS (continued)

### Switch SW-A

ARMING CHARACTERS				ARMING CHARACTER SWITCH POSITIONS							
ASCII	CTRL	HEX	DECIMAL	LSB 1	2	3	4	5	6	7	MSB 8
US	_	1F	31	0	0	0	0	0	C	C	C
SPACE		20	32	C	C	C	C	C	0	C	C
!		21	33	0	C	C	C	C	0	C	C
"		22	34	C	0	C	C	C	0	C	C
#		23	35	0	0	C	C	C	0	C	C
\$		24	36	C	C	0	C	C	0	C	C
%		25	37	0	C	0	C	C	0	C	C
&		26	38	C	0	0	C	C	0	C	C
'		27	39	0	0	0	C	C	0	C	C
(		28	40	C	C	C	0	C	0	C	C
)		29	41	0	C	C	0	C	0	C	C
.		2A	42	C	0	C	0	C	0	C	C
+		2B	43	0	0	C	0	C	0	C	C
,		2C	44	C	C	0	0	C	0	C	C
-		2D	45	0	C	0	0	C	0	C	C
_		2E	46	C	0	0	0	C	0	C	C
/		2F	47	0	0	0	0	C	0	C	C
0		30	48	C	C	C	C	0	0	C	C
1		31	49	0	C	C	C	0	0	C	C
2		32	50	C	0	C	C	0	0	C	C
3		33	51	0	0	C	C	0	0	C	C
4		34	52	C	C	0	C	0	0	C	C
5		35	53	0	C	0	C	0	0	C	C
6		36	54	C	0	0	C	0	0	C	C
7		37	55	0	0	0	C	0	0	C	C
8		38	56	C	C	C	0	0	0	C	C
9		39	57	0	C	C	0	0	0	C	C
:		3A	58	C	0	C	0	0	0	C	C
;		3B	59	0	0	C	0	0	0	C	C
<		3C	60	C	C	0	0	0	0	C	C
=		3D	61	0	C	0	0	0	0	C	C
>		3E	62	C	0	0	0	0	0	C	C

## 2.2.2 AUTO-TIMEOUT, SWITCH TIME & RS 232/422

### Switch SW-T

POSITION	DESCRIPTION	SETTINGS
1 & 2	Auto Time Out (after data transmission)	<u>1</u> <u>2</u>
		CL CL 0.5 min
		OP CL 1.5 min
		CL OP 7.3 min
OP OP Infinite/Disable		
3	S-Port Allow Switch Time	CL = Enable; OP = Disable
4	Allows S-Port to select a connection to M-Port	
5	M-Port Allow Switch Time	
6	Allows M-Port to select a connection to S-Port	
7	M-Port RS232/RS422 select	CL = 232, OP = 422 (see NOTE)
8	S-Ports RS232/RS422 select	

**NOTE:** RS422 configurable in the field for M-Port and S-Ports 0 - 3 only; S-Ports 4 - 15 must be configured at the factory.

## 2.2.3 HANDSHAKE CONTROL, PORT DECODER & POWER-ON RESET

### Switch SW-C

POSITION	DESCRIPTION	SETTINGS
1	BREAK transmission for a received Framing Error or receive Parity Error	CL = Disable; OP = Enable
2	S-Port handshake use TRE for /CIN_M	
3	M-Port handshake use TRE for /CIN_S	
4	Reset to Switch Time. Caused by a drop of Subordinate Port CIN_S	
5	Control Line Out while in ST	
6	Port Decoder in ST	
7	Reset to Switch Time. Caused by a drop of Master Port CIN_M	
8	Extended port decode	CL = Limits to ports 0 - 7 OP = Enables ports 0 - 15

## 2.2.4 DATA FORMAT

### Switch SW-F

POSITION	DESCRIPTION	SETTINGS
1	Word Length	CL=8 bits, OP=7 bits
2	Stop Bits	CL=1 stop, OP=2 stop
3	Parity	CL= Odd Parity; OP= Even Parity
4	Parity Enable	CL= Disabled; OP= Enabled
5, 6 & 7	High Baud Rate <i>(Factory default – See p. 6 for Low Baud Rate option)</i>	<u>5</u> <u>6</u> <u>7</u> CL CL CL = 1200 OP CL CL = 4800 CL OP CL = 9600 OP OP CL = 19,200 CL CL OP = 38,400 OP CL OP = 57,600 CL OP OP = 76,800 OP OP OP = 115,200
8	Transceiver Loop Back	CL = No Loop Back; OP=Loop Back (troubleshooting only)

## 2.2.5 POWER-ON PORT SELECTION & GRAPHICS MODE

### Switch SW-P

POSITION	DESCRIPTION	SETTINGS
1 – 4	Power-on Port Selection	<u>1</u> <u>2</u> <u>3</u> <u>4</u> CL CL CL CL = Port 0 OP CL CL CL = Port 1 CL OP CL CL = Port 2 OP OP CL CL = Port 3 CL CL OP CL = Port 4 OP CL OP CL = Port 5 CL OP OP CL = Port 6 OP OP OP CL = Port 7 CL CL CL OP = Port 8 OP CL CL OP = Port 9 CL OP CL OP = Port 10 OP OP CL OP = Port 11 CL CL OP OP = Port 12 OP CL OP OP = Port 13 CL OP OP OP = Port 14 OP OP OP OP = Port 15
5 & 6	Graphics Mode Gap Timing	<u>5</u> <u>6</u> CL CL = 5 Word Gap in transmission OP CL = 25 Word Gap in transmission CL OP = 50 Word Gap in transmission OP OP = 100 Word Gap in transmission
7 & 8	Graphics Mode Timer Reset	<u>7</u> <u>8</u> CL CL = M-Port ↔ S-Port character Bi-direction OP CL = M-Port ← S-Port character received CL OP = M-Port → S-Port character received OP OP = Reset Disabled

## 2.2.6 ARMING CODE SETTINGS

### Switch SW-A

ARMING CHARACTERS				ARMING CHARACTER SWITCH POSITIONS							
ASCII	CTRL	HEX	DECIMAL	LSB 1	2	3	4	5	6	7	MSB 8
NUL	@	00	0	C	C	C	C	C	C	C	C
SOH	A	01	1	O	C	C	C	C	C	C	C
STX	B	02	2	C	O	C	C	C	C	C	C
ETX	C	03	3	O	O	C	C	C	C	C	C
EOT	D	04	4	C	C	O	C	C	C	C	C
ENQ	E	05	5	O	C	O	C	C	C	C	C
ACK	F	06	6	C	O	O	C	C	C	C	C
BEL	G	07	7	O	O	O	C	C	C	C	C
BS	H	08	8	C	C	C	O	C	C	C	C
HT	I	09	9	O	C	C	O	C	C	C	C
LF	J	0A	10	C	O	C	O	C	C	C	C
VT	K	0B	11	O	O	C	O	C	C	C	C
FF	L	0C	12	C	C	O	O	C	C	C	C
CR	M	0D	13	O	C	O	O	C	C	C	C
SO	N	0E	14	C	O	O	O	C	C	C	C
SI	O	0F	15	O	O	O	O	C	C	C	C
DLE	P	10	16	C	C	C	C	O	C	C	C
DC1	Q	11	17	O	C	C	C	O	C	C	C
DC2	R	12	18	C	O	C	C	O	C	C	C
DC3	S	13	19	O	O	C	C	O	C	C	C
DC4	T	14	20	C	C	O	C	O	C	C	C
NAK	U	15	21	O	C	O	C	O	C	C	C
SYN	V	16	22	C	O	O	C	O	C	C	C
ETB	W	17	23	O	O	O	C	O	C	C	C
CAN	X	18	24	C	C	C	O	O	C	C	C
EM	Y	19	25	O	C	C	O	O	C	C	C
SUB	Z	1A	26	C	O	C	O	O	C	C	C
ESC	[	1B	27	O	O	C	O	O	C	C	C
FS	\	1C	28	C	C	O	O	O	C	C	C
GS	]	1D	29	O	C	O	O	O	C	C	C
RS	^	1E	30	C	O	O	O	O	C	C	C